

REVISIONS			
REV.	DESCRIPTION	DATE	APPROVED
-	NEW RELEASE	-	-
1	MOUNTING BRACKET WAS FABRICATED NOW PURCHASED. PLATE WASHERS WERE FABRICATED NOW PURCHASED.	4/21/2026	F. BRYANT

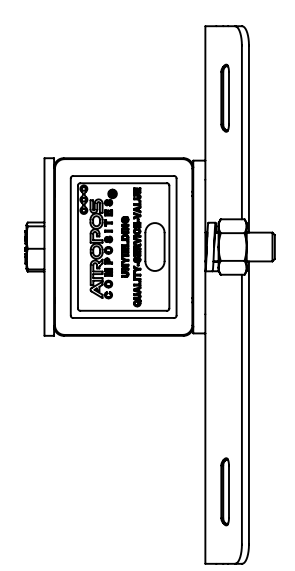
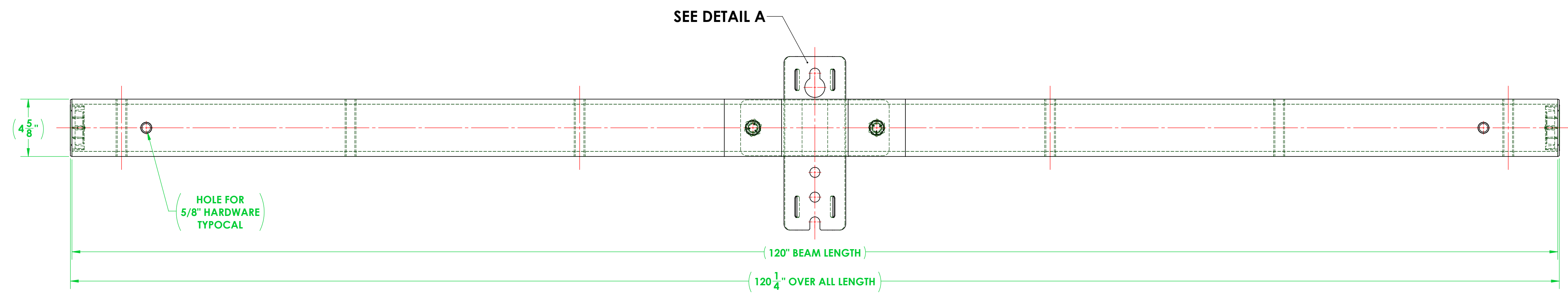
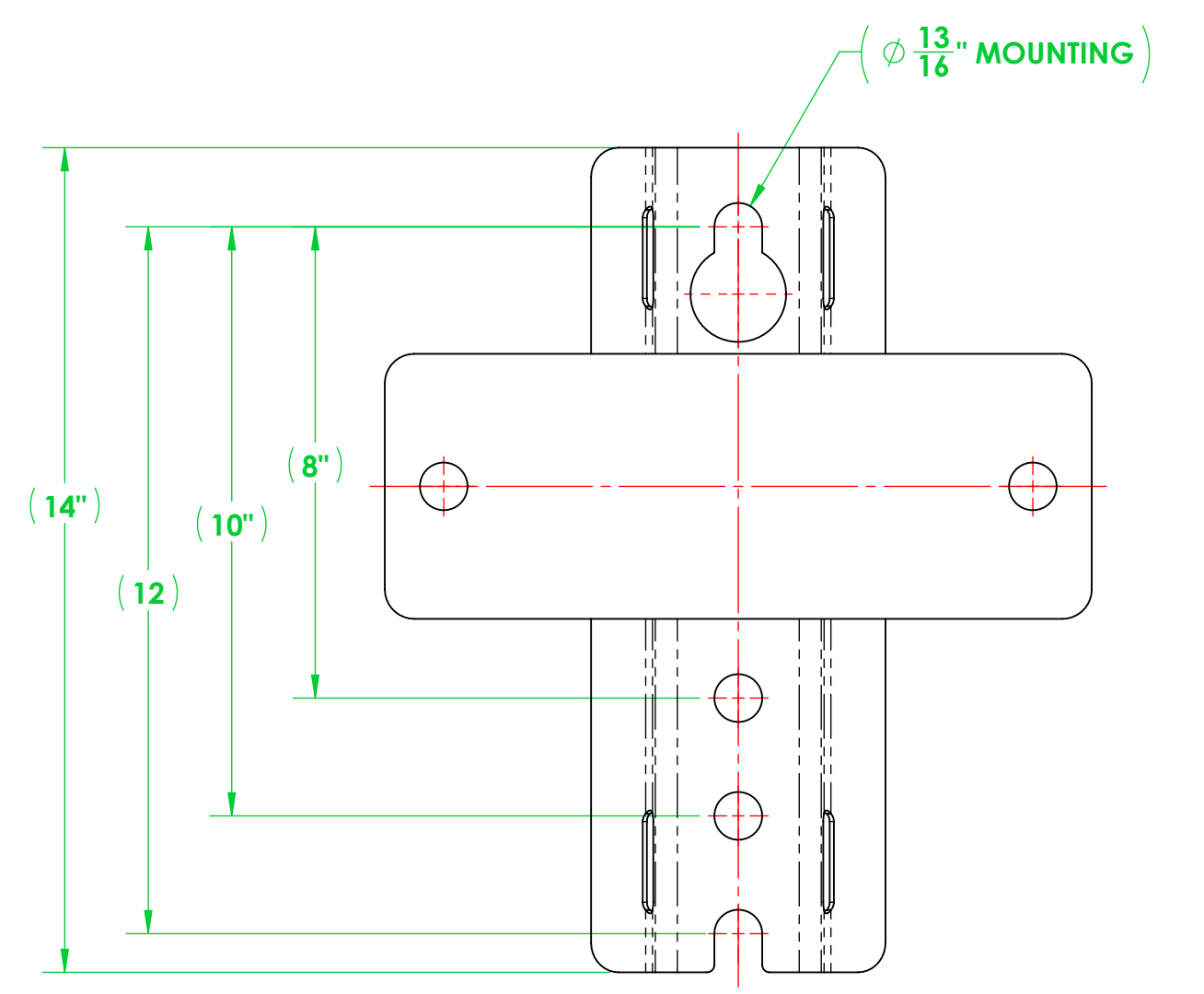
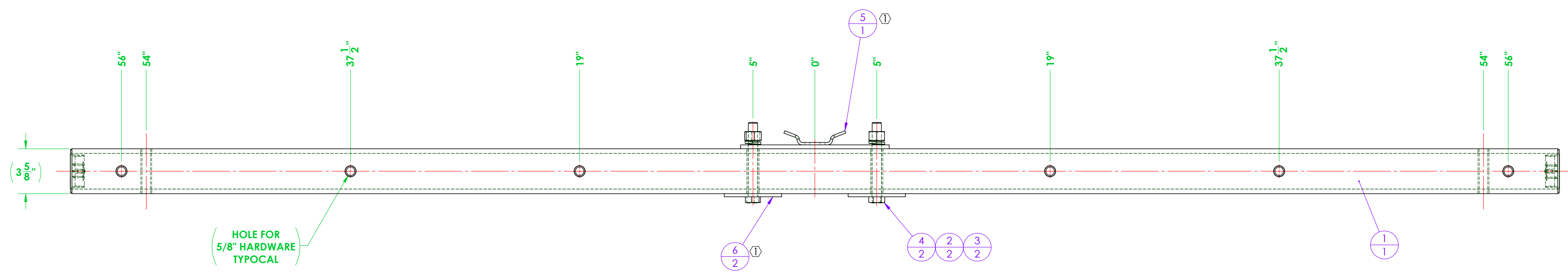

ITEM NO.	PART NUMBER	DESCRIPTION	QTY.
1	3403A120-T011-XR05 CA	ASSEMBLY, RUS, 3403 TANGENT CROSSARM, 10' LONG TYPE 5 DRILL PATTERN	1
2	A616-0042-01	LOCK WASHER, FOR 3/4" SCREW, 0.766" ID, 1.265" OD, 0.188" THICK, HOT-DIPPED GALVANIZED STEEL	2
3	A616-0019-02	EXTREME STRENGTH NUT, HEX, 3/4"-10, 2H, HOT-DIPPED GALVANIZED	2
4	A616-0020-02	BOLT, HEX, 3/4"-10 X 6.00" LONG, HOT DIPPED GALVANIZED STEEL, 1-1/8" DRIVE	2
① 5	A700-0042	CROSSARM MOUNTING BRACKET, TANGENT, 3400 SERIES	1
① 6	A700-0047	WASHER, SQUARE, 4.625" X 4.625" X 0.25 THICK WITH 0.81 THRU HOLE	2

GENERAL NOTES DIMENSIONS ARE IN INCHES STANDARD TOLERANCES FRACTIONAL: $\pm 1/32$ ANGULAR: MACHINED $\pm 0.5^\circ$ BEND $\pm 2^\circ$ TWO PLACE DECIMAL: ± 0.03 THREE PLACE DECIMAL: ± 0.005 INTERPRET GEOMETRIC TOLERANCING PER ANSI Y14.5 MATERIAL FINISH DO NOT SCALE DRAWING	UNLESS OTHERWISE SPECIFIED NAME DATE	DRAWN: F. BRYANT 10/14/2025 CHECKED: TJS 10/21/2025 ENG APPR: MFG APPR: Q.A.	ATROPOS COMPOSITES 12208 MISSOURI BOTTOM ROAD, HAZELWOOD, MO 63042 PHONE: 314.714.4001 FAX: 314.895.1943 SALES@LABYRINTHTECH.COM
	PROPRIETARY AND CONFIDENTIAL THE INFORMATION CONTAINED IN THIS DRAWING IS THE SOLE PROPERTY OF VETURIO. ANY REPRODUCTION IN PART OR AS A WHOLE WITHOUT THE WRITTEN PERMISSION OF VETURIO IS PROHIBITED.		TITLE: ASSEMBLY, RUS, 3403, TANGENT CROSSARM WITH GAIN, 10' TYPE 5 DRILL PATTERN
	SIZE DWG. NO. D 3403A120-T011-XR05	REV 1	SCALE: 1:8 WEIGHT: 83.23 SHEET 1 OF 1